

SCHNITT A-A

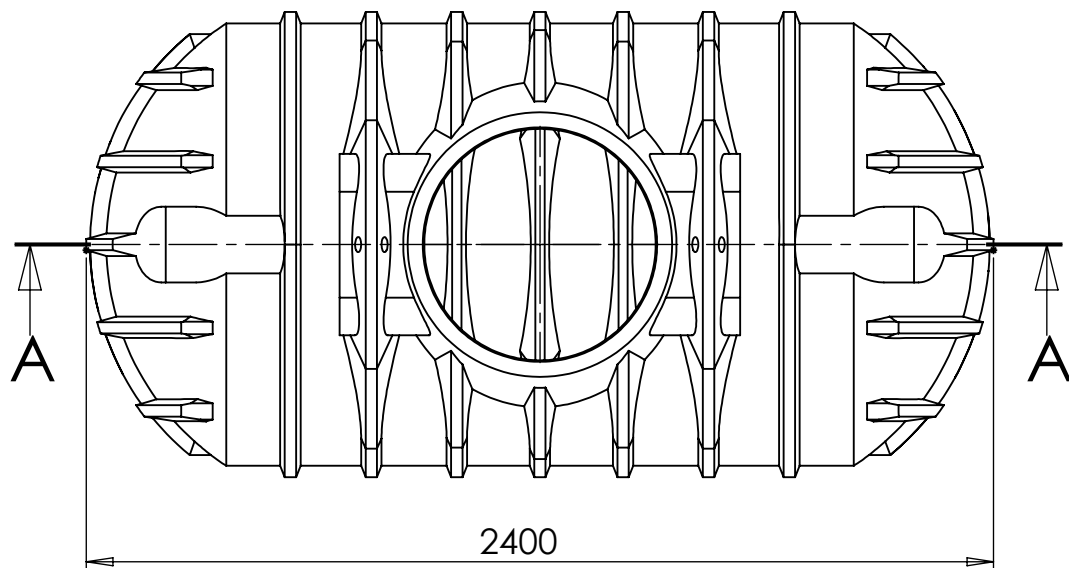
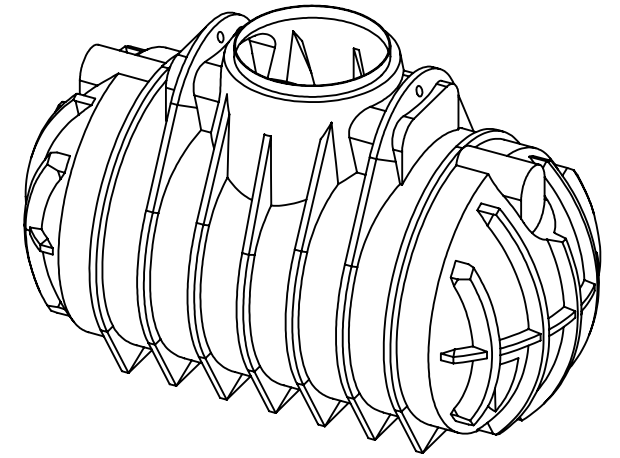
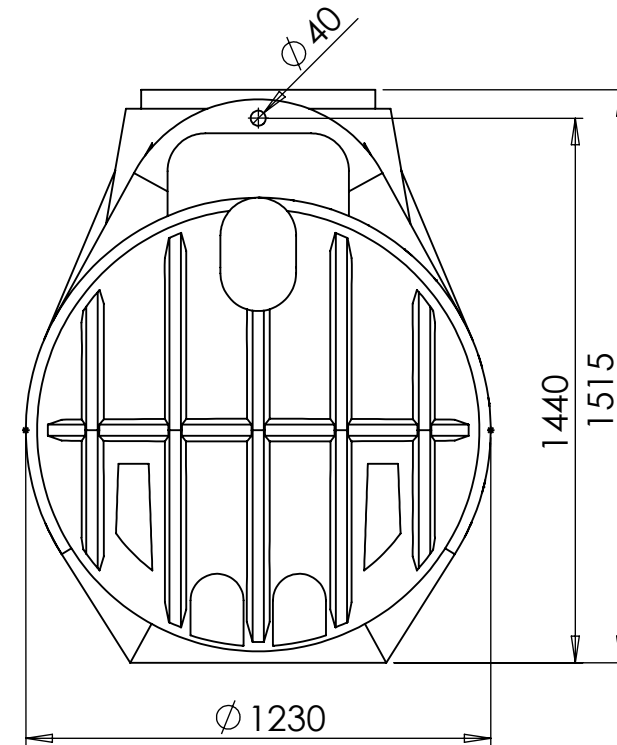
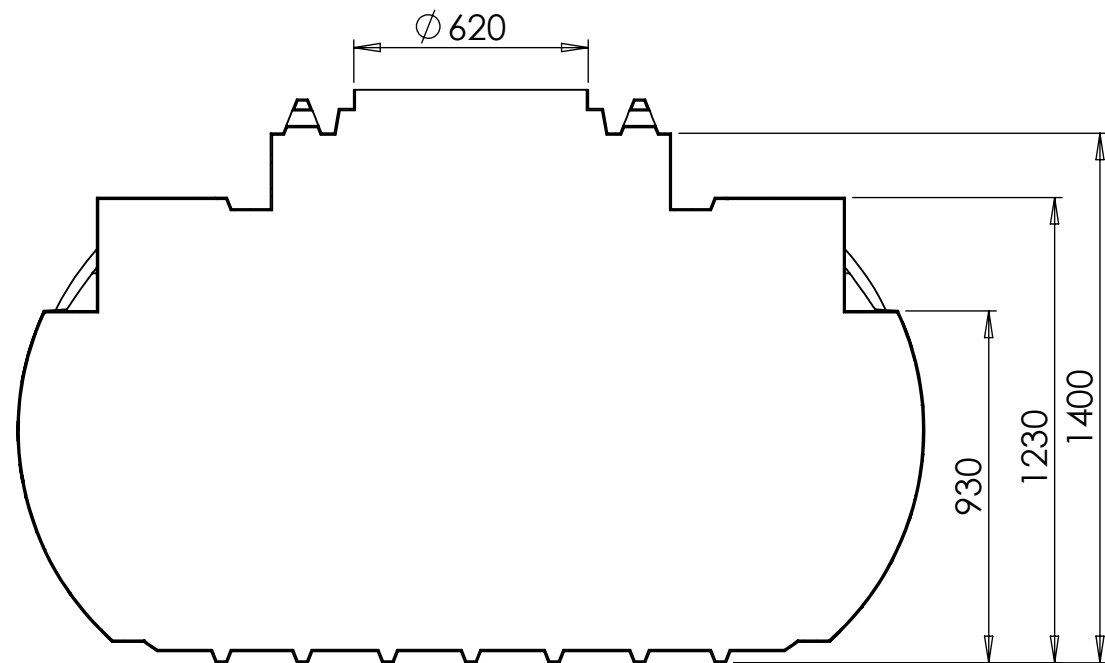

Beilage-Set

74.6000.0930 Hinweis-Aufkleber Spedition

Hinweis

Verfahrensbedingte Toleranz +/- 3% sind zulässig

Benennung geändert	SW2011	001		F.Trende 01.08.11	J.Gramke 01.08.11	
frei für Vorserie	SW2010	000	-	-	-	-
Änderungsindex/Planquadrat/Änderungsbeschreibung State or revision/grid square/Revision text	CAD	ZGS	Auftrags-Nr. order no.	Bearb./auth. Datum/date	Pruef./check Datum/date	Norm/stand. Datum/date
Werkstoff (Endzustand) material (final condition)	Oberfläche/surface (mm ²)		25.27814	Datum/date	Name/name	
LLDPE	Farbe/color		-	Bearb./auth.	24.03.10	F.Trende
-	Oberflächenschutz		-	Pruef./check	-	-
-	Oberfl. ang./surf. texture		DIN EN ISO 1302	Norm/stand.	-	-
-	Masse/mass (kg)		47.23613	Freig./rel.	-	-
Allg.Toleranzen/gen. tolerances Rotationsstelle DIN ISO 16901 160A	Allg.Toleranzen/gen.tolerances Metallbau DIN 2768-1	CAD	Solid Works	ZGS	001	Auftr.-Nr./order no.
	Masstab/scale 1:20	Benennung/title Atlantis 2200 L o.A. Erdspeicher				
		Kundenzeichnung/customer drawing Datum/date				
Schutzvermerk nach DIN ISO 16016 beachten! Refer to protection notice DIN ISO 16016!	Format/size A3	Blatt/sheet 1	Sach-Nr./basic number 35.2000.0000			